

STEREO AMPLIFIER

SA-6500II

SERVICE MANUAL



CONTENTS

1.	SPECIFICATIONS	2
2.	FRONT PANEL FACILITIES	3
3.	CONNECTION DIAGRAM	4
4.	BLOCK DIAGRAM	5
5.	LEVEL DIAGRAM	7
6.	CIRCUIT DESCRIPTION	
6.1	Equalizer Amplifier (Q_1)	8
6.2	Tone Control (Q_2, Q_3)	8
6.3	Power Amplifier ($Q_4 - Q_{11}$)	8
6.4	Muting Circuit (Fig. 1)	8
6.5	Protection Circuit (Fig. 2)	8
7.	DISASSEMBLY	10
8.	PARTS LOCATION	
8.1	Front Panel View	12
8.2	Front View With Panel Removed	13
8.3	Top View With Cover Removed	14
8.4	Rear Panel View	15
9.	ADJUSTMENT	16
10.	EXPLODED VIEWS	17
11.	SCHMATIC DIAGRAMS, P.C. BOARD PATTERNS AND PARTS LIST	
11.1	Miscellaneous Parts List	23
11.2	Schematic Diagram	25
11.3	AF Amplifier Assembly (AWK-083)	27
12.	PACKING	34

1. SPECIFICATIONS

Semiconductors

ICs	2
Transistors	25
Diodes	16

Amplifier Section

Circuitry

Power amplifier 1st stage differential amplifier
direct-coupled OCL

Equalizer amplifier 1-stage differential amplifier
3-stage direct-coupled

Control amplifier 2-stage direct-coupled

Continuous Power Output from 20 Hertz to 20,000 Hertz
(Both channels driven) . . 30 watts per channel (8 ohms)
30 watts per channel (4 ohms)

Total Harmonic Distortion at 20Hertz to 20,000Hertz from
AUX.

Continuous rated power output 0.1%

15watts per channel power output, 8ohms 0.05%

1 watt per channel power output, 8ohms 0.05%

Intermodulation Distortion

Continuous rated power output 0.1%

15watts per channel power output, 8ohms 0.05%

1 watt per channel power output, 8ohms 0.05%

Speakers A, B, A + B

Headphones Low impedance

Damping Factor (20Hertz to 20,000Hertz, 8ohms) . . . 30

Input (Sensitivity/Impedance)

PHONO 2.5mV/50kohms

TUNER 150mV/50kohms

AUX 150mV/50kohms

TAPE PLAY 1 150mV/50kohms

TAPE PLAY 2 150mV/50kohms

PHONO Overload Level (T.H.D. : 0.1%): 200mV (1kHz)

Output (Level/Impedance)

TAPE REC 1 150mV

TAPE REC 2 150mV

Frequency Response

PHONO (RIAA Equalization) 20Hz to 20,000Hz
 ± 0.3 dB

TUNER, AUX, TAPE PLAY 10Hz to 40,000Hz
 ± 1 dB

Tone Control

BASS +9dB, -8dB (100Hz)

TREBLE +8dB, -6dB (10kHz)

Loudness Contour (Volume control set at -40dB position)
. +8dB (100Hz), +5dB (10kHz)

Hum and Noise (IHF, short-circuited, A network, rated
power)

PHONO 72dB

TUNER, AUX, TAPE PLAY 93dB

Miscellaneous

Power Requirements 120V 60Hz only

Power Consumption 100watts (UL)
220VA (CSA), 300watts (Max.)

Dimensions 380(W) x 139(H) x 308(D)mm
15(W) x 5-1/2(H) x 12-1/8(D)in.

Weight. Without Package: 7.6kg (16lb 12oz)
With Package: 8.6kg (19lb)

Furnished Parts

Operating Instructions 1

NOTE:

Specifications and the design subject to possible modification without notice due to improvements.

2. FRONT PANEL FACILITIES

BASS AND TREBLE CONTROLS

Controls for adjusting low and high frequency tone. With the TONE switch in the ON position, turn controls clockwise to enhance low or high frequencies and counter-clockwise to attenuate their respective frequency ranges.

SPEAKERS SWITCH

Selects speaker system operation.

OFF: Sound not obtained from speakers (when using headphones).

A: Sound obtained from speakers connected to A speaker terminals.

B: Sound obtained from speakers connected to B speaker terminals.

A + B: Sound obtained from speakers connected to both A and B speaker terminals.

NOTE:

When listening with headphones or to temporarily interrupt the speaker sound, set switch to OFF or to an unused speaker position.

VOLUME CONTROL

Adjusts volume from speakers and headphones. Clockwise rotation increases volume.

BALANCE CONTROL

Adjusts relative left and right channel volume balance between speaker systems and headphones. If the right channel volume is insufficient, turn the control clockwise from center. Conversely, if the left channel volume is insufficient, turn the control counter-clockwise from center.

FUNCTION SWITCH

Selects desired playback program source.

PHONO: To play records on a turntable connected to the PHONO jacks.

TUNER: To listen to broadcasts with a tuner connected to the TUNER jacks.

AUX: To play a component connected to the AUX jacks.

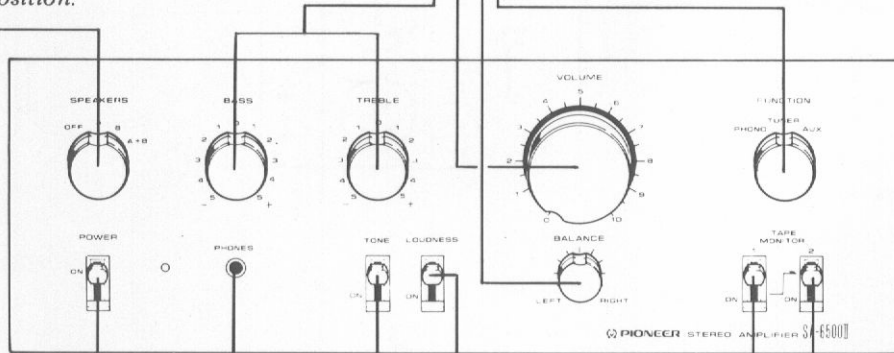

POWER SWITCH

Set to ON position to energize SA-6500II. After setting to ON, there is a brief delay before sound is obtained. This is due to the operation of the muting circuit which prevents noise when the POWER is switched. This function does not indicate difficulty and normal operating condition is attained in a few seconds. The POWER switch also controls the rear panel SWITCHED convenience outlets.

PHONES JACK

When listening with stereo headphones, connect them to this jack.

NOTE:

Set SPEAKERS switch to OFF when listening only with headphones.

LOUDNESS SWITCH

When listening at low volume settings, set switch to ON to enhance low and high frequencies. The response of the human ear to sound differs according to loudness. This switch compensates for this effect at low volumes.

TAPE MONITOR (1 & 2) SWITCHES

Employ for tape playback or to monitor a recording in progress.

- 1: Playback or monitoring of a tape deck connected to the TAPE 1 (REC & PLAY) jacks.
- 2: Playback or monitoring of a tape deck connected to the TAPE 2 (REC & PLAY) jacks.

NOTES:

- Be sure to set switches to upper (OFF) position when playing records or listening to broadcasts.
- When recording with two tape decks simultaneously, do not operate the TAPE MONITOR 1 switch as this will interrupt the signal to the TAPE 2 deck.

TONE SWITCH

In the ON position, tone adjustments can be performed with the BASS and TREBLE controls. When set to the upper (OFF) position, the tone control circuits are disengaged and frequency response is flat. This function is convenient for checking cartridge and speaker tone quality and listening room acoustics.

3. CONNECTION DIAGRAM

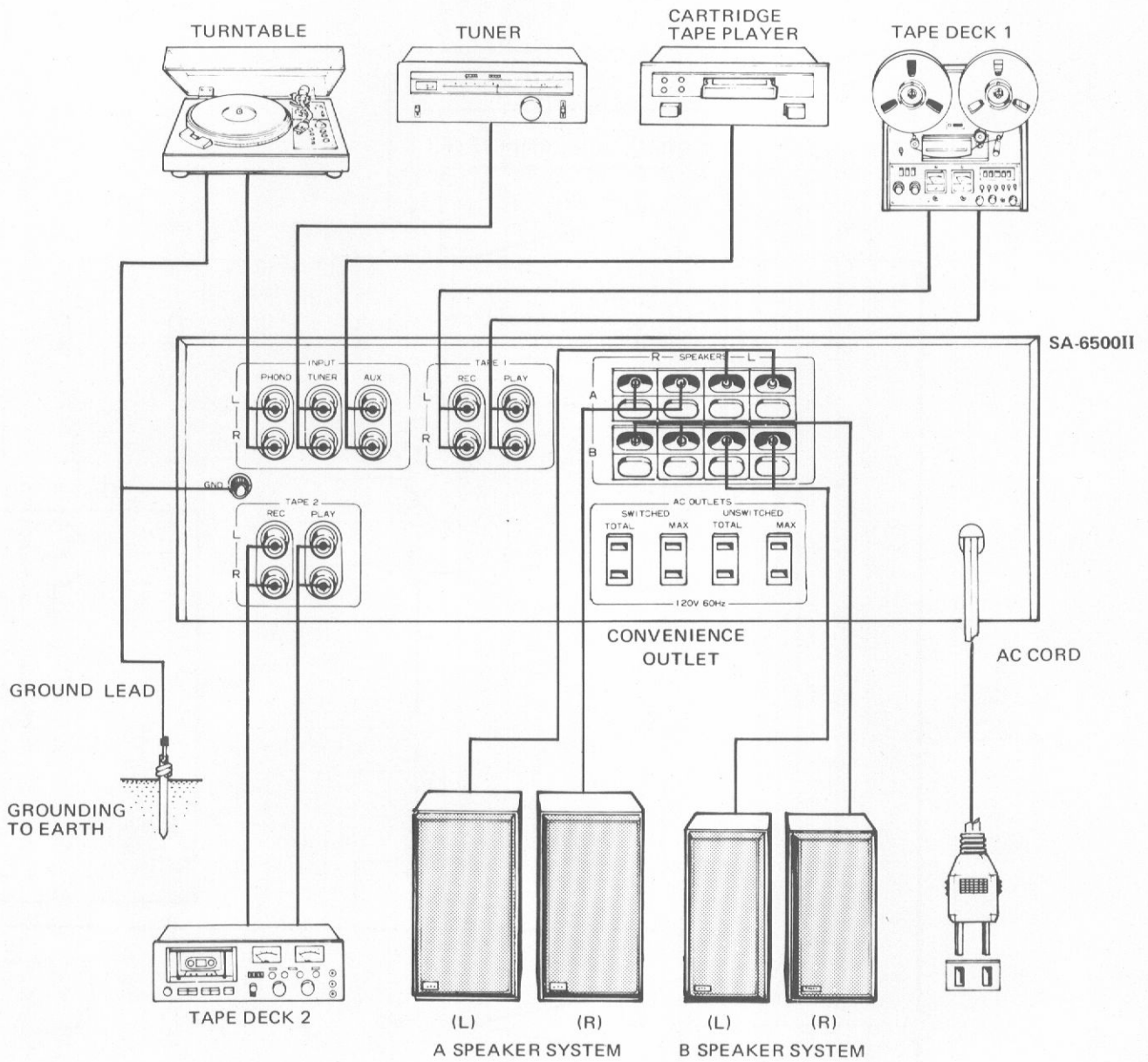

4. BLOCK DIAGRAM

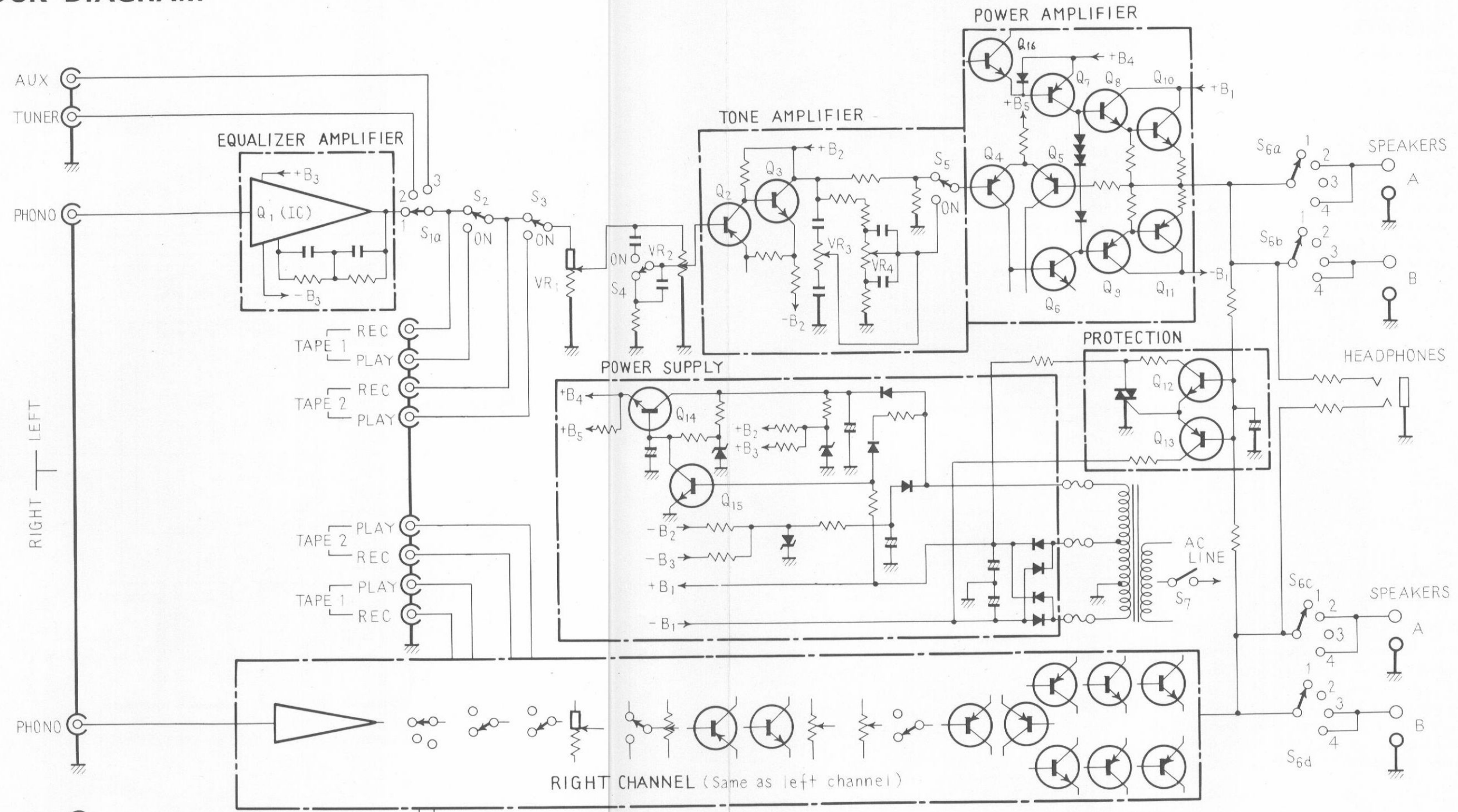

- NOTES :
- | | | | |
|---|--|------------------------------------|---------------------------|
| S ₁ : FUNCTION
1. PHONO 2. TUNER 3. AUX | S ₄ : LOUDNESS
OFF ↔ ON | S ₇ : POWER
OFF ↔ ON | VR ₁ : BALANCE |
| S ₂ : TAPE MONITOR 1
OFF ↔ ON | S ₅ : TONE
OFF ↔ ON | | VR ₂ : VOLUME |
| S ₃ : TAPE MONITOR 2
OFF ↔ ON | S _{6a~d} : SPEAKERS
1. SP OFF 2. A 3. B 4. A+B | | VR ₃ : TREBLE |
| | | | VR ₄ : BASS |

5. LEVEL DIAGRAM

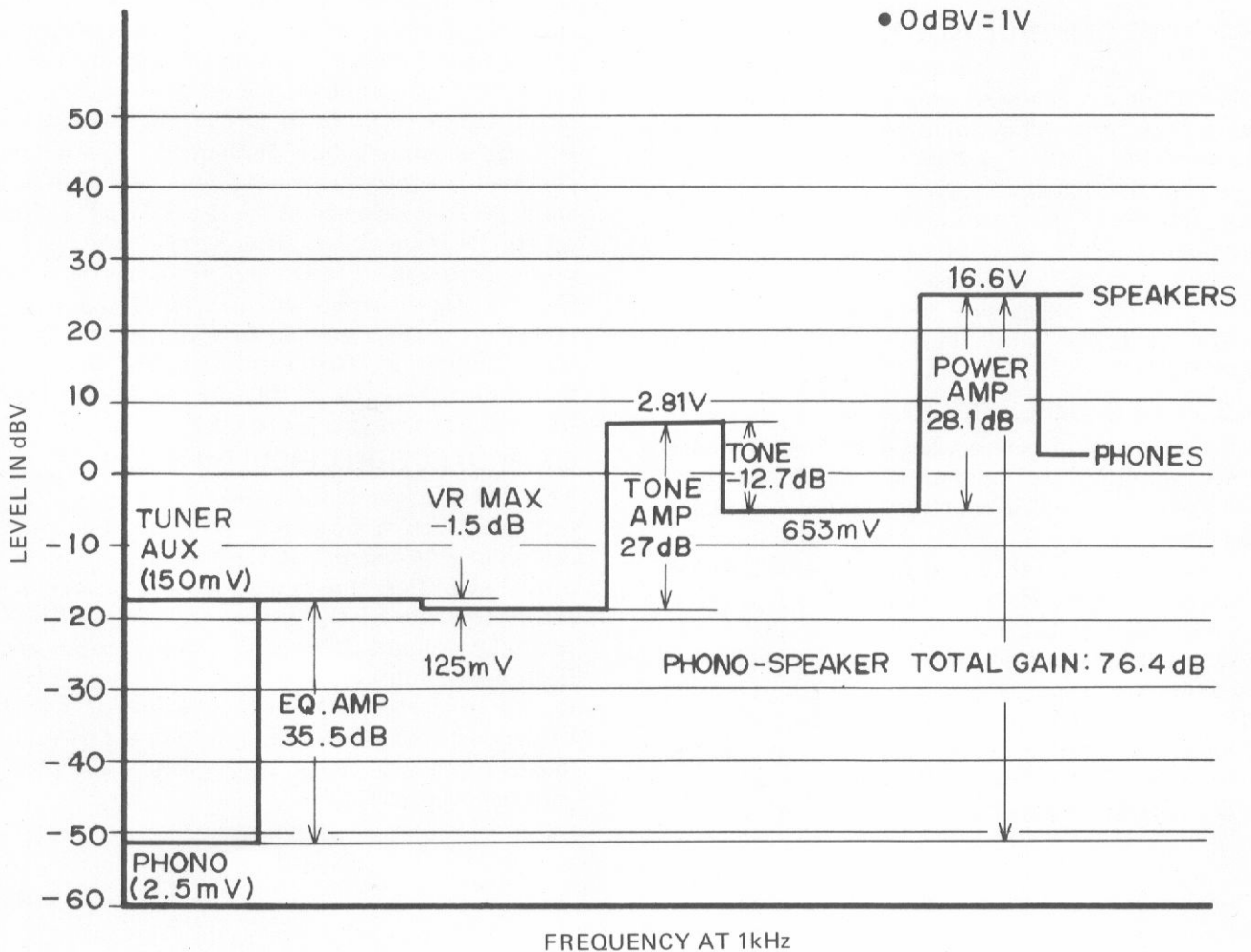
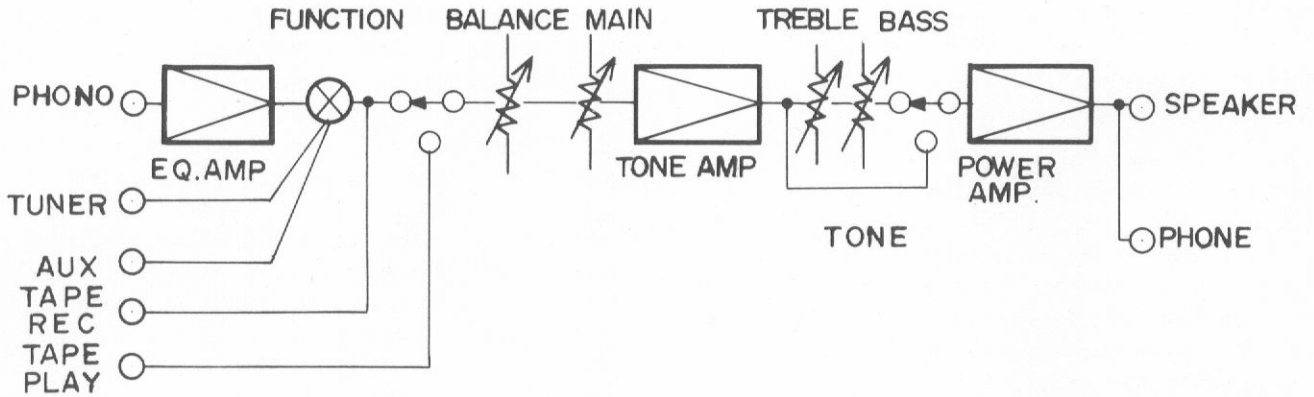

6. CIRCUIT DESCRIPTION

The SA-6500II is a 2-channel integrated stereo amplifier. The descriptions given here mainly refer to the left channel. Please refer to the block diagram on pages 5 ~ 6.

6.1 EQUALIZER AMPLIFIER (Q_1)

The equalizer amplifier is a high gain IC with a first stage differential amplifier, final stage emitter-follower and 3 stages direct coupled. The RIAA curve is obtained by using sufficient negative feedback. The elements which govern the RIAA response are 1% tolerance metallized film resistors and 2% tolerance polystyrene capacitors. RIAA deviation in the range from 20Hz to 20,000Hz is guaranteed within ± 0.3 dB of the standard value. At the same time, high reliability is obtained with respect to thermal variations and aging. Since this IC also possesses high voltage endurance (43V), maximum nominal input at 1kHz is 200mVrms (at 0.1% T.H.D.).

6.2 TONE CONTROL (Q_2, Q_3)

A RC network tone control system is used. The attenuator circuits used each consist of a capacitor and a resistor. They increase and decrease the relative levels of high and low frequency sound. Because the attenuator gives relative control over the frequency response, there is constant loss. To compensate for this, an amplifier (Q_2, Q_3) is employed prior to this stage.

The control ranges are +8dB to -6dB for the highs (at 10kHz) and +9dB to -8dB for the lows (at 100Hz).

6.3 POWER AMPLIFIER ($Q_4 - Q_{11}$)

This is a basic direct-coupled pure complementary OCL amplifier. Its operation is stabilized by the differential amplifier which is driven by a balanced power supply.

Q_4 and Q_5 form a differential amplifier: 100% d.c. feedback is applied from the junction point of the power stage to the base of Q_5 so the potential of the junction point is always maintained at the same level.

The driver and output stages are Darlington connected and a perfectly complementary symmetrical circuit is formed using PNP and NPN transistors; this ensures dynamic balance at different inputs.

6.4 MUTING CIRCUIT (Fig. 1)

This muting circuit, shown in Fig. 1, functions to reduce shock noise and residual sound when the POWER switch is operated ON-OFF.

POWER switch ON muting: Q_{15} base is immediately reverse biased by $-B_1$ and becomes OFF. Q_{14} emitter, voltage gradually increases due to the gradual charging of C_3 in the base circuit by $+B_1$ through $R_4 \sim R_6$. Since the power amplifier first stage and predriver obtain voltage supply from Q_{14} emitter, operation begins 2 to 3 seconds after the POWER switch has been set to ON. This delay time is determined by the time constant of $R_4 \sim R_6$ and C_3 . Since the equalizer and tone amplifiers attain normal operation during this interval, shock noise produced in these circuits when the POWER switch is set to ON does not reach the output.

POWER switch OFF muting: $-B_1$ immediately reaches ground potential and $+B_2$ forward biases Q_{15} base through R_8 . Q_{15} turns ON, C_3 is discharged, and Q_{14} turns OFF. Consequently, the power amplifier first stage and predriver stage also turns OFF and residual sound does not reach the output. Since Q_{16} turns ON at the same time as Q_{15} , C_4 is immediately discharged. This circuit is designed to prevent disturbance to the power amplifier DC balance when the POWER switch is set to ON immediately after setting to OFF. If the power switch is set to ON before C_4 has discharged, Q_7 (Constant current circuit) turns ON and the predriver stage begins to operate before the first stage operation. This results in the DC balance being disturbed. C_4 is therefore discharged when the POWER switch is set to OFF.

6.5 PROTECTION CIRCUIT (Fig. 2)

This circuit protects the speakers from any possible damage. Then a potential of more than +4V or less than -4V occurs at the junction point in the power amplifier, this circuit causes the fuse in the secondary side of the power transformer to blow within 2 seconds. This cuts off the power amplifier's power supply.

D_1 is a tri-electrode AC switch (a type of thyristor) which can control switching in either direction by means of its gate signal. Both positive and negative gate signals turn it ON.

The bases of Q_{12} and Q_{13} are connected to the junction point of the power amplifier. The emitters of Q_{12} and Q_{13} are connected to the gate of D_1 and the emitter resistor R_E is common to both (Fig. 2).

When a positive potential occurs at the junction point of the power amplifier, current flows through the NPN transistor Q_{12} but not through PNP transistor Q_{13} . Current flowing through Q_{12} to R_E causes the voltage across R_E to drop. Because of this, positive voltage is supplied to the gate of D_1 .

When a negative potential occurs at the junction point of the power amplifier, current flows through Q_{13} and not through Q_{12} .

This the voltage drop across R_E causes a negative voltage at the gate of D_1 .

When the potential at the junction point of the power amplifier exceeds $\pm 4V$, the voltage drop across R_E exceeds the gate trigger voltage of D_1 , and D_1 turns ON. With D_1 turned ON, a large current flows through the power circuit which blows the fuse on the secondary side of the power transformer.

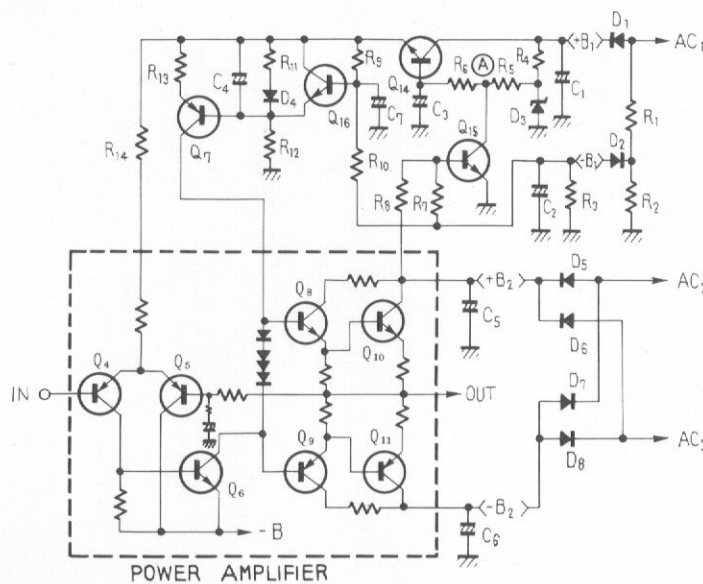

Fig. 1 Muting Circuit

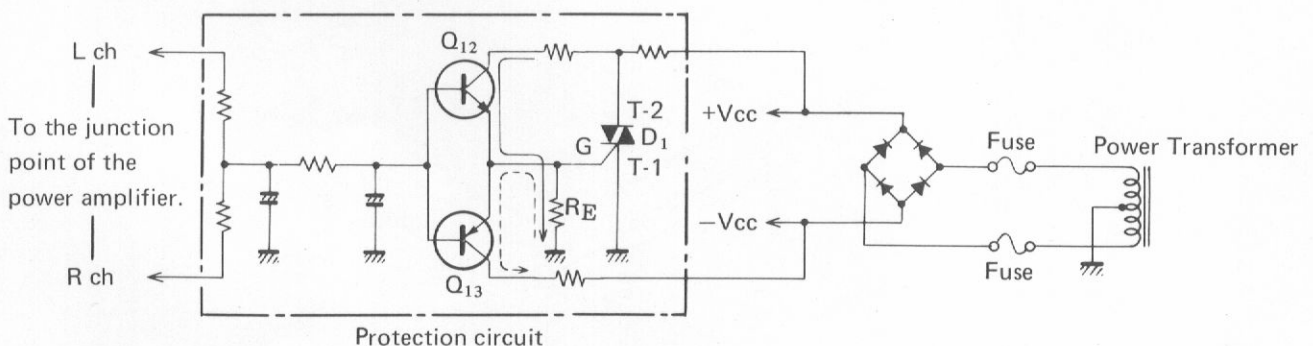

Fig. 2 Protection circuit

7. DISASSEMBLY

● Remove the Top Cover

1. Remove the 1 ~ 4 screws on the each side of the top cover as shown in Fig. 3.

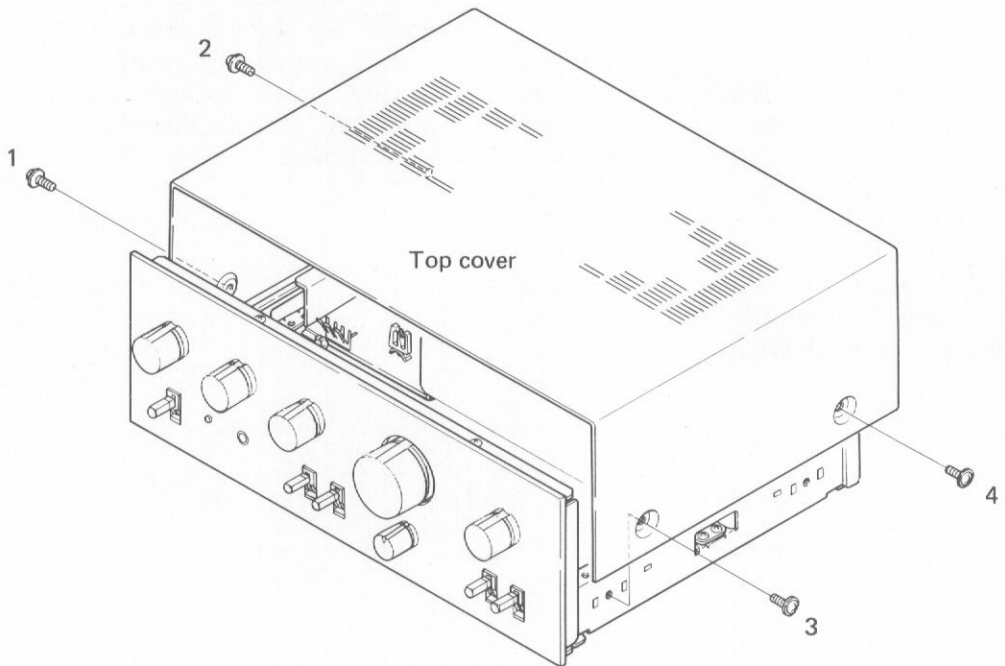

Fig. 3

● Remove the Bottom Panel

1. Remove the 1 ~ 9 screws to detach the bottom panel as shown in Fig. 4.

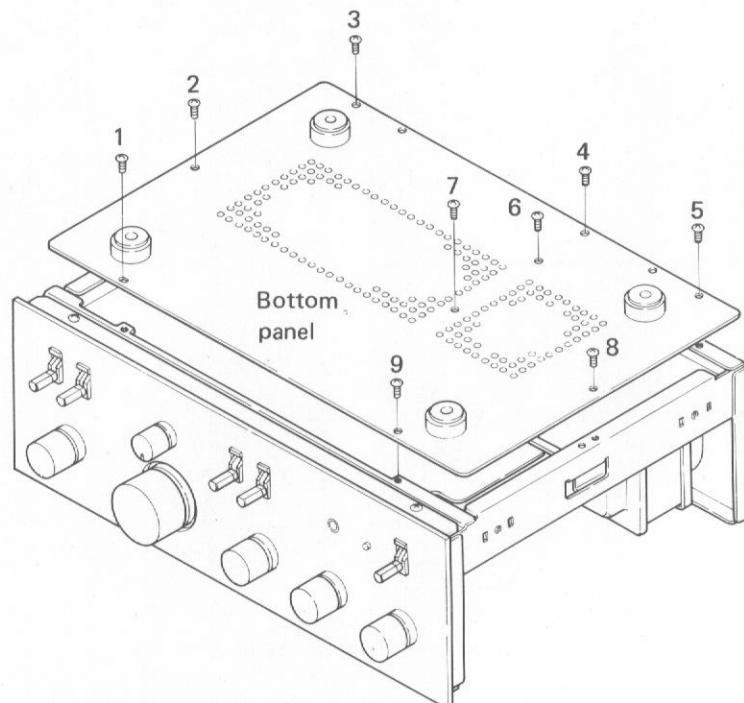

Fig. 4

● **Remove the Front Panel**

1. Remove the all control knobs by pulling.
2. Remove the 1 ~ 4 screws to detach the front panel, as shown in Fig. 5

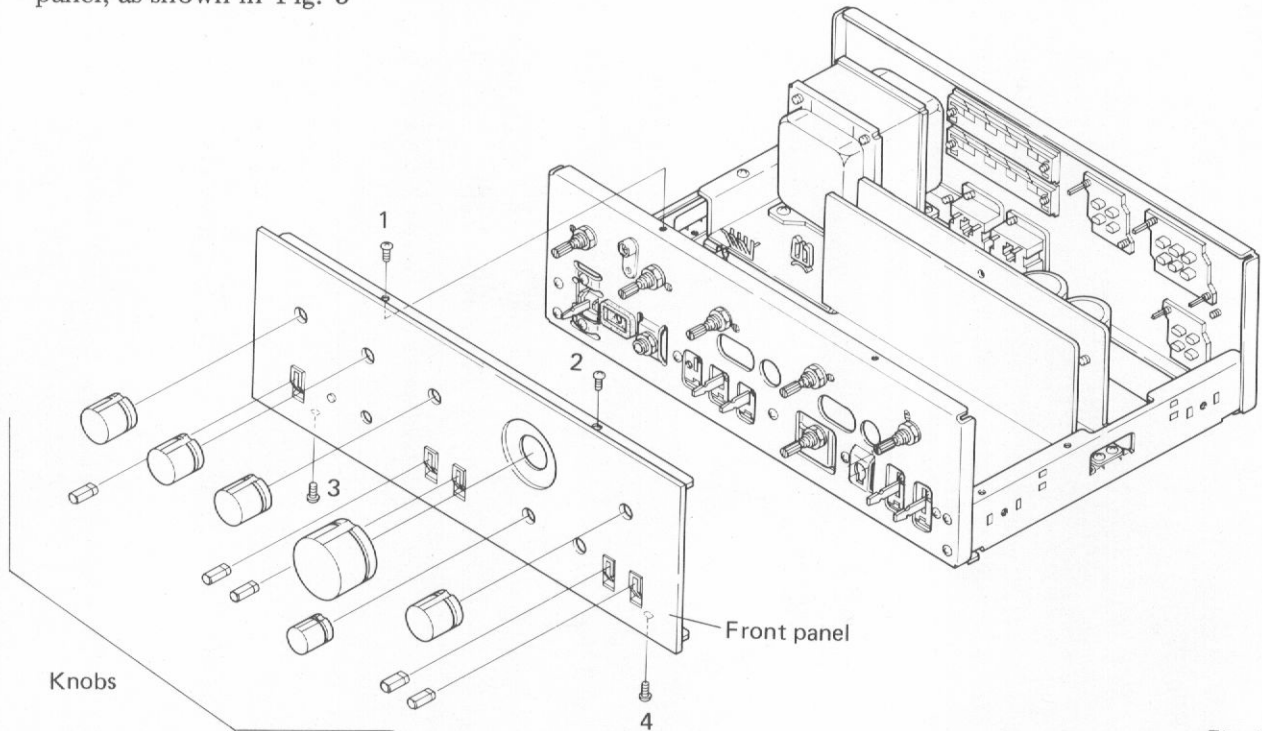

Fig. 5

● **Remove the AF Amplifier Assembly**

1. Remove the top cover, bottom panel and front panel.
2. Remove the 1 ~ 9 screws which mount the P.C.B. on the chassis, as shown in Fig. 6.

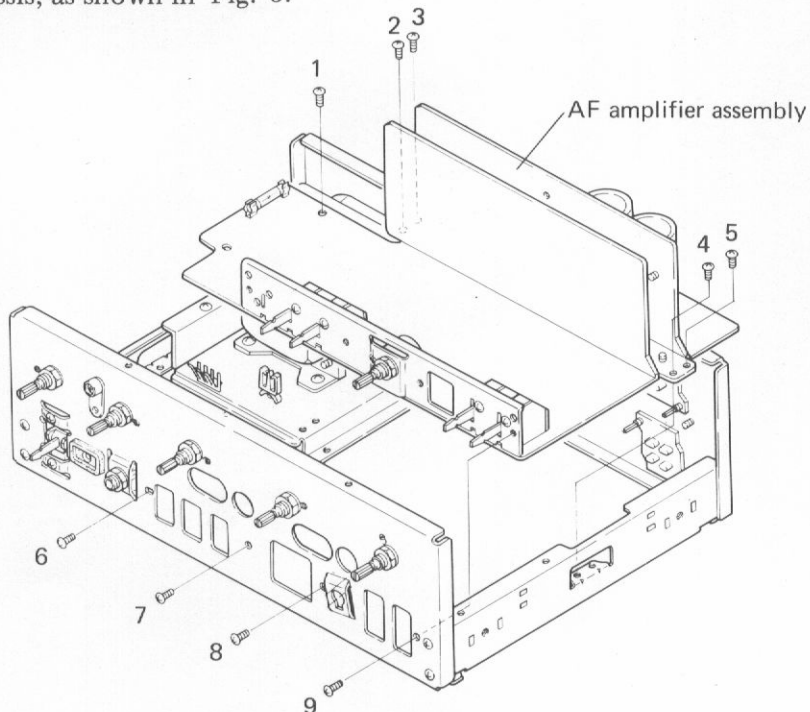
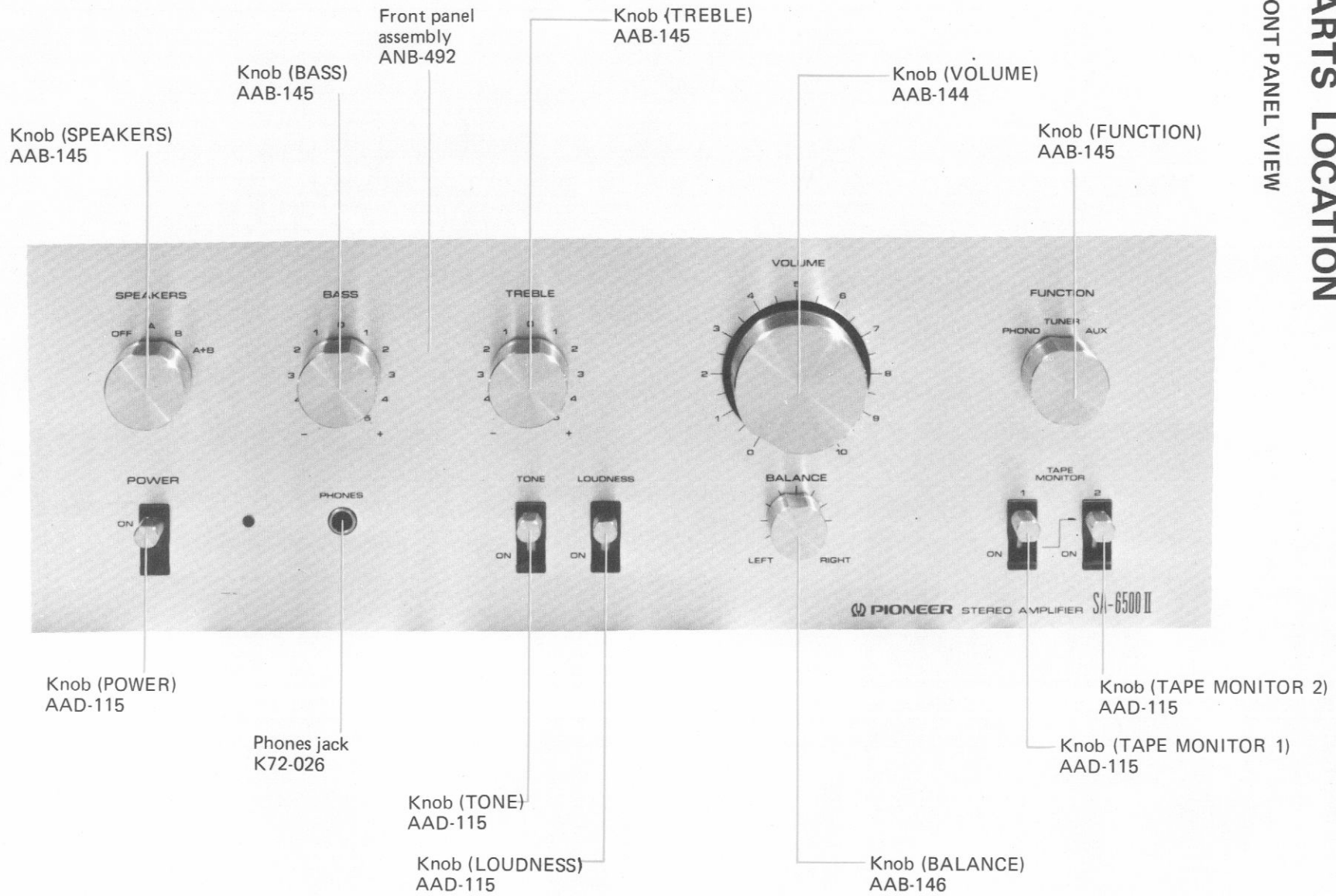
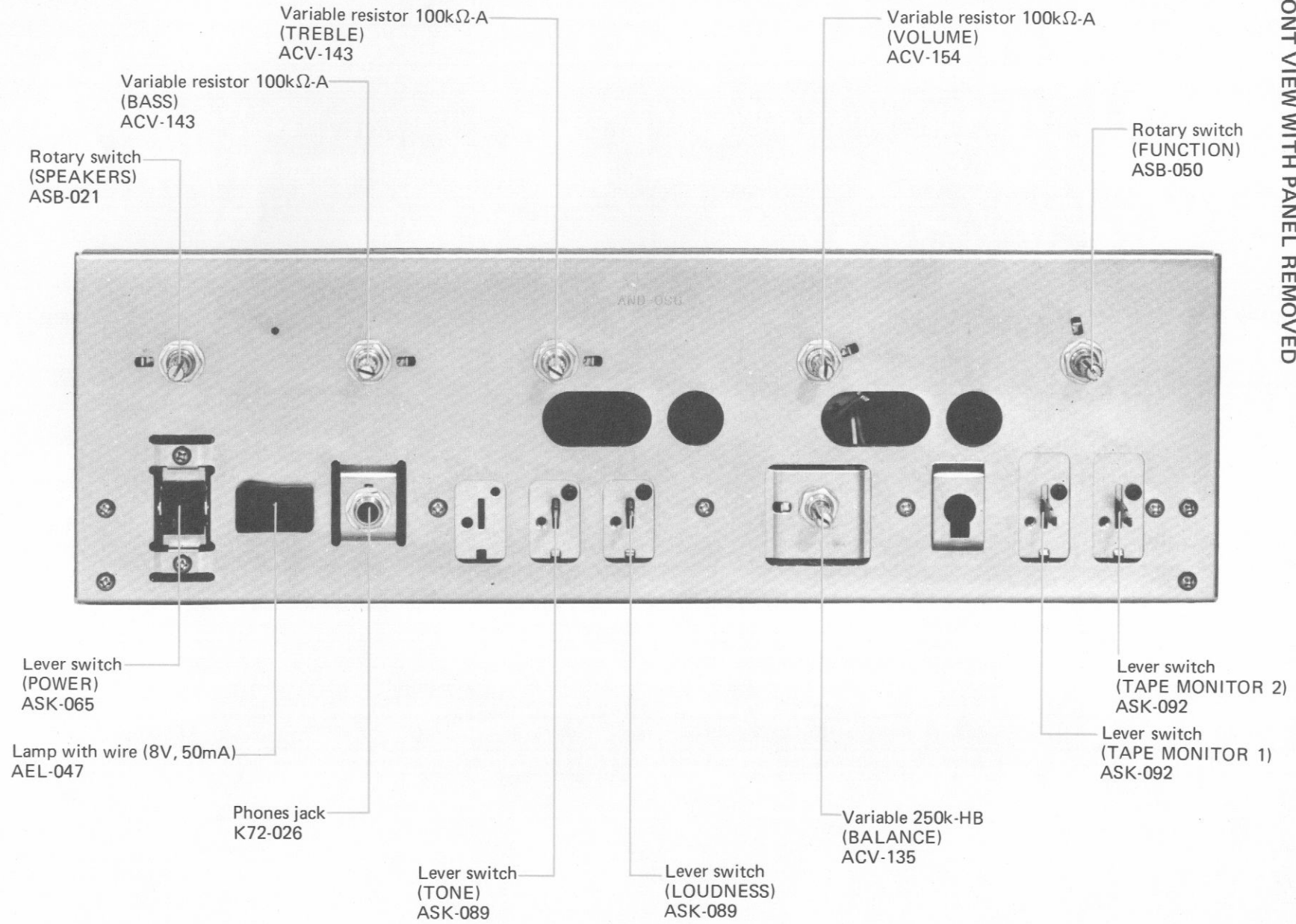

Fig. 6

8. PARTS LOCATION

8.1 FRONT PANEL VIEW





8.3 TOP VIEW WITH COVER REMOVED

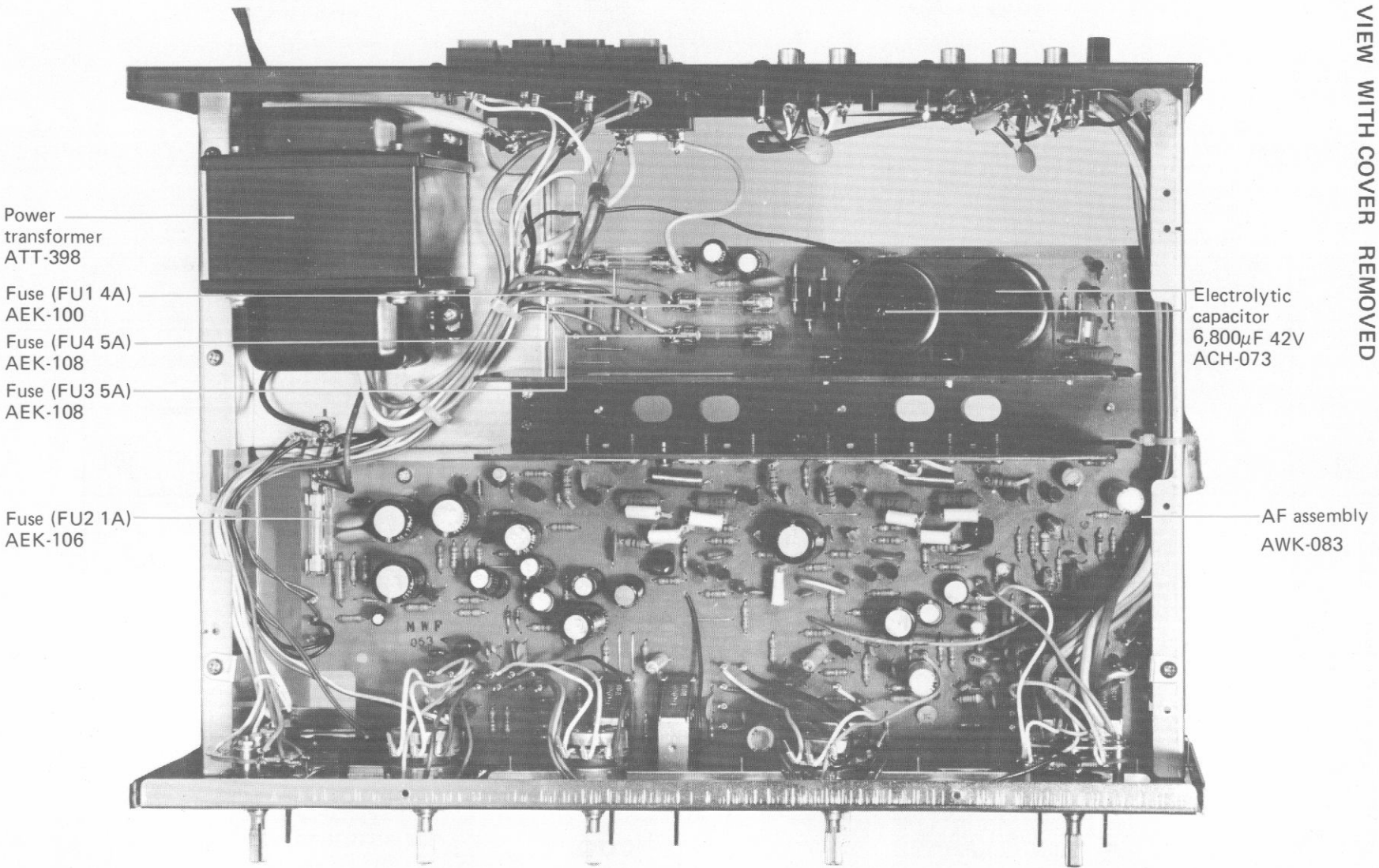

Power transformer
ATT-398

Fuse (FU1 4A)
AEK-100

Fuse (FU4 5A)
AEK-108

Fuse (FU3 5A)
AEK-108

Fuse (FU2 1A)
AEK-106

Electrolytic capacitor
6,800 μ F 42V
ACH-073

AF assembly
AWK-083

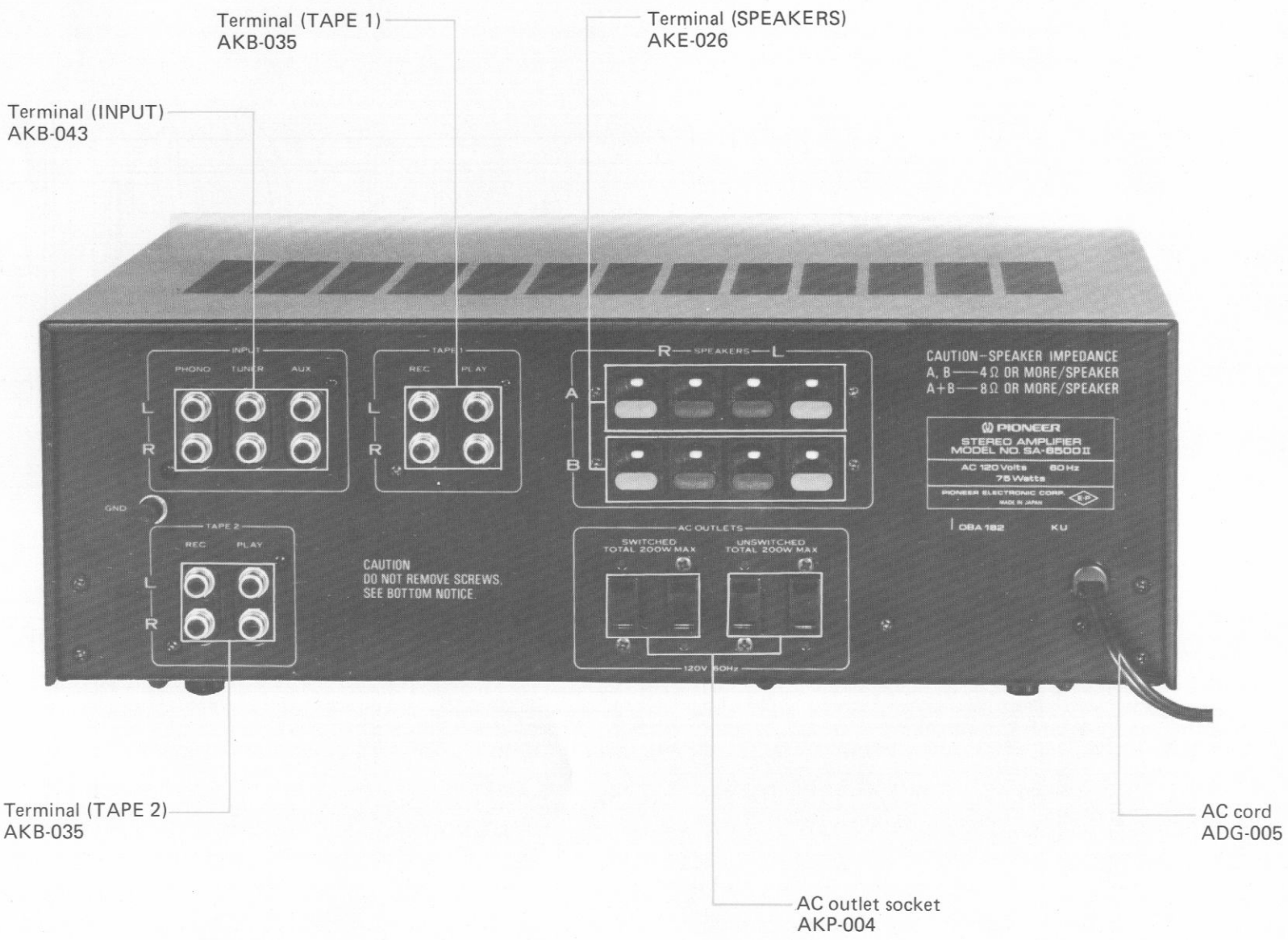

9. ADJUSTMENT

- This adjustment should be performed only when any of the transistors in the power amplifier have been replaced.
 - For adjustment, wait 10 minutes after the POWER switch is turned ON.
1. Set the VOLUME control to minimum.
 2. Connect as shown in Fig. 7.
 3. Cut the jumper lead A: right channel, B: for left channel, if the voltage is less than 10mV reading on the DC millivolt meter.

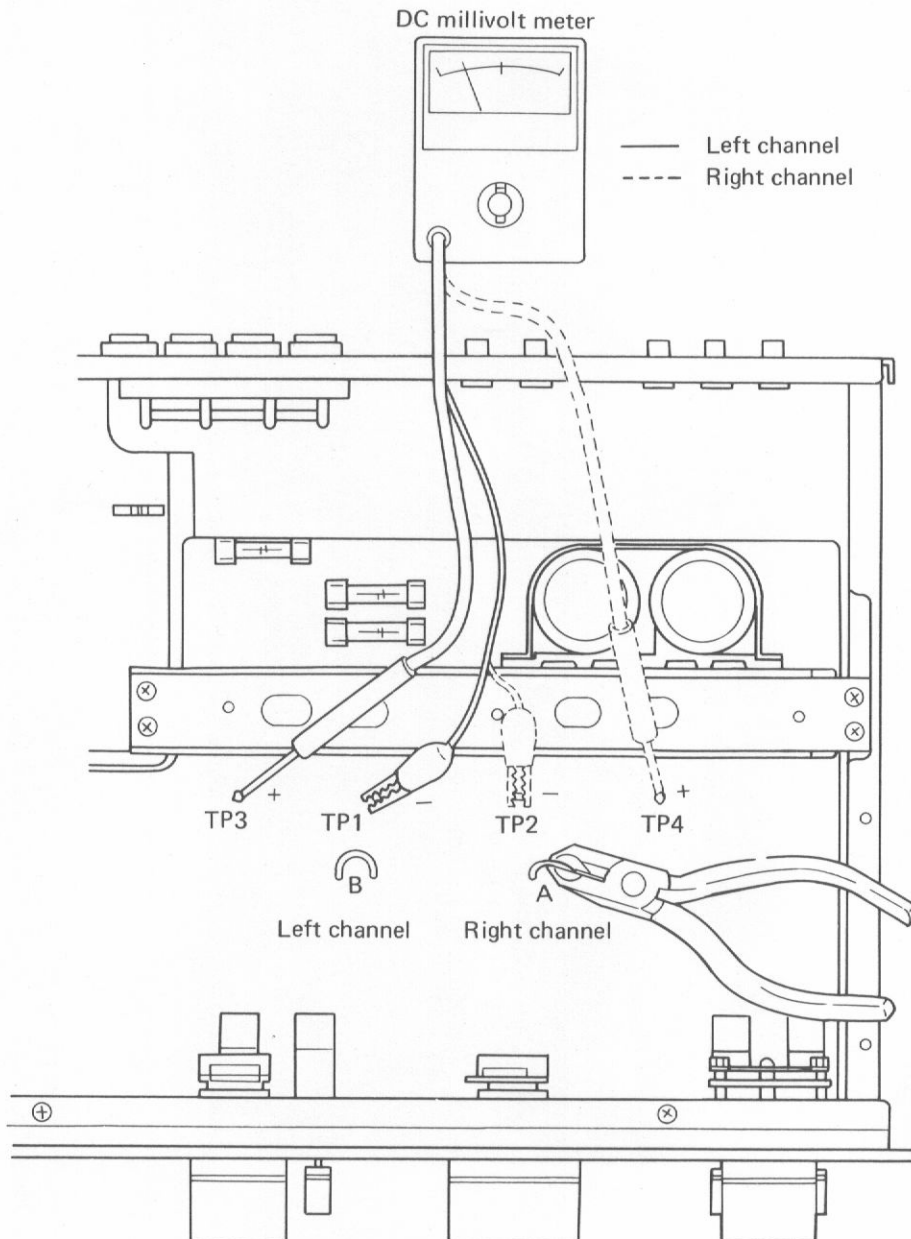

Fig. 7 Connection Diagram of Idle Current Adjustment



10. EXPLODED VIEWS

Exterior

The following symbols stand for screws as shown in exploded views.

NOTE:

- Parts indicated in green type cannot be supplied.
- All screws are phillips (cross recess) type.

Symbol	Description	Shape
RT	Brazier head tapping screw	
BT	Binding head tapping screw	

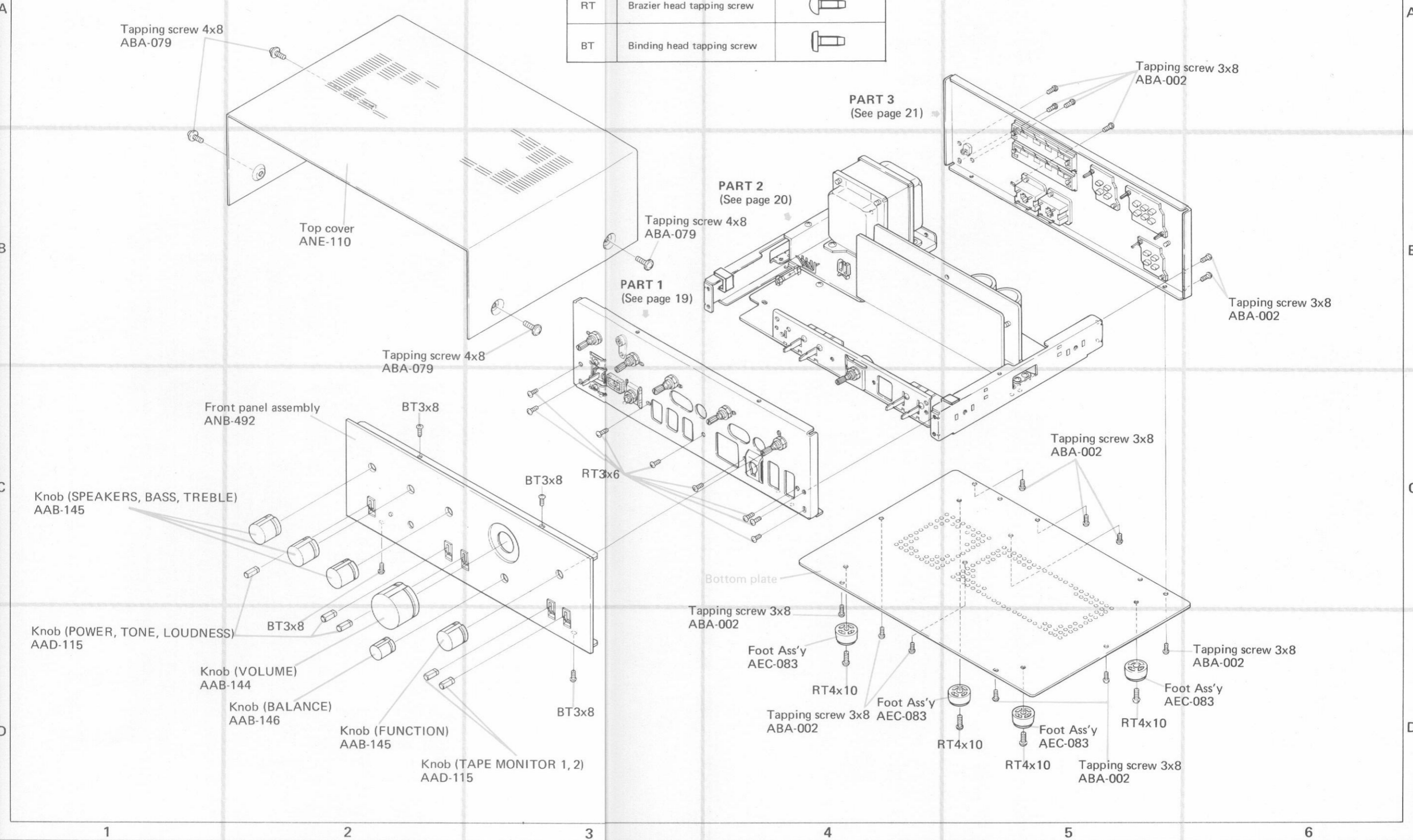

Part 1

NOTE:

- Parts indicated in green type cannot be supplied.
- All screws are phillips (cross recess) type.

Rotary switch (SPEAKERS)
ASB-021

Lever switch (POWER)
ASK-065

Variable resistor (BASS)
100kΩ-A
ACV-143

Variable resistor (TREBLE)
100kΩ-A
ACV-143

Variable resistor (VOLUME)
100kΩ-A
ACV-154

Rotary switch (FUNCTION)
ASB-050

Phones jack
K72-026

Stopper ring
RT3x8

Panel stay

Rubber holder
AEB-064

Lamp with wire 8V, 50mA
AEL-047

Washer faced nut 9φ
ABN-024

RT3x6

Part 2

NOTE:

- Parts indicated in green type cannot be supplied.
- All screws are phillips (cross recess) type.

A

A

B

B

C

C

D

D

1 2 3

1 2 3

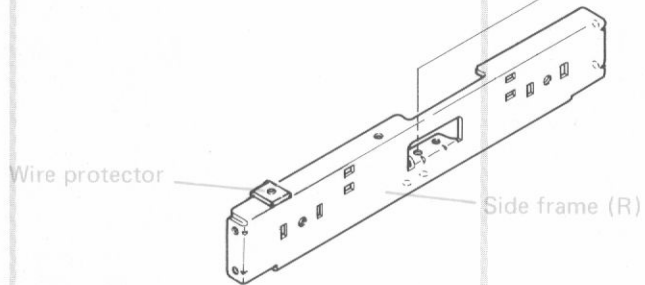
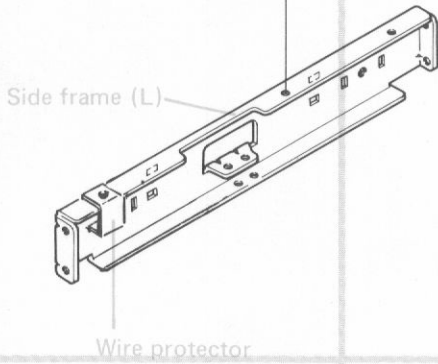
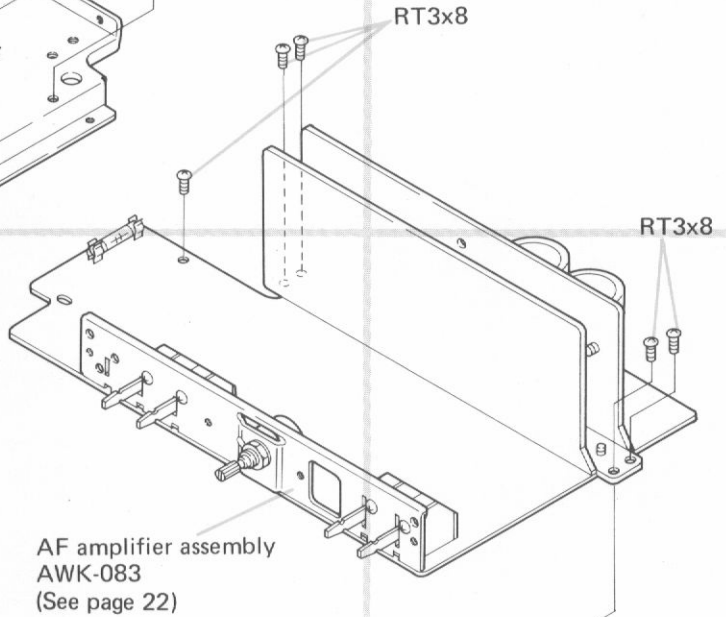
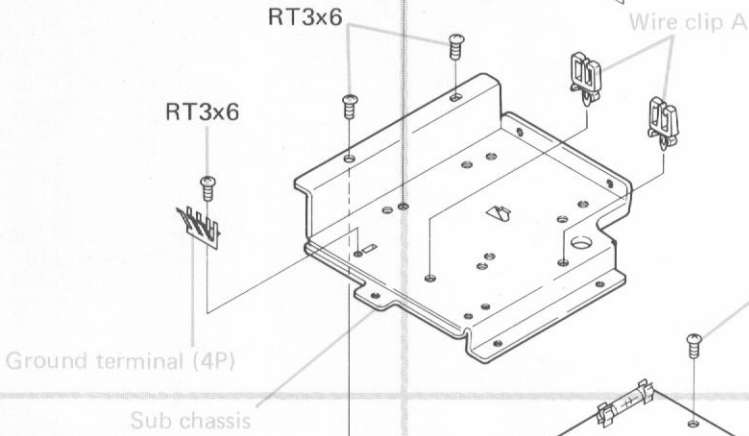
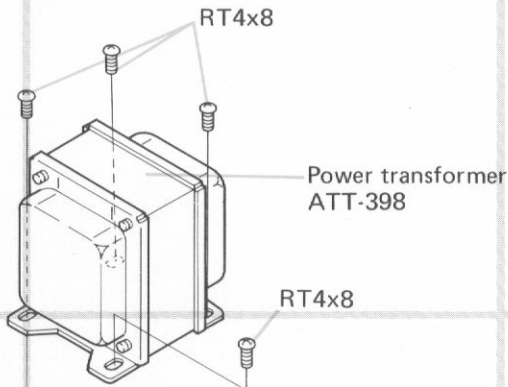

Part 3

NOTE:

- Parts indicated in green type cannot be supplied.
- All screws are phillips (cross recess) type.

Strain relief
AEC-079

AC cord
ADG-005

Machine screw 3x8
ABA-003

Tapping screw 3x10
ABA-082

Rear panel

Special screw
ABA-115

Washer 4φ
ABE-005

Terminal (GND)
AKE-031

Tapping screw 3x10
ABA-082

Terminal (SPEAKERS)
AKE-026

Terminal (TAPE 1)
AKB-035

Terminal (TAPE 2)
AKB-035

AC outlet socket
AKP-004

Terminal (INPUT)
AKB-043

1 AF Amplifier Assembly (AWK-083)

NOTE:

- Parts indicated in green type cannot be supplied.
- All screws are phillips (cross recess) type.

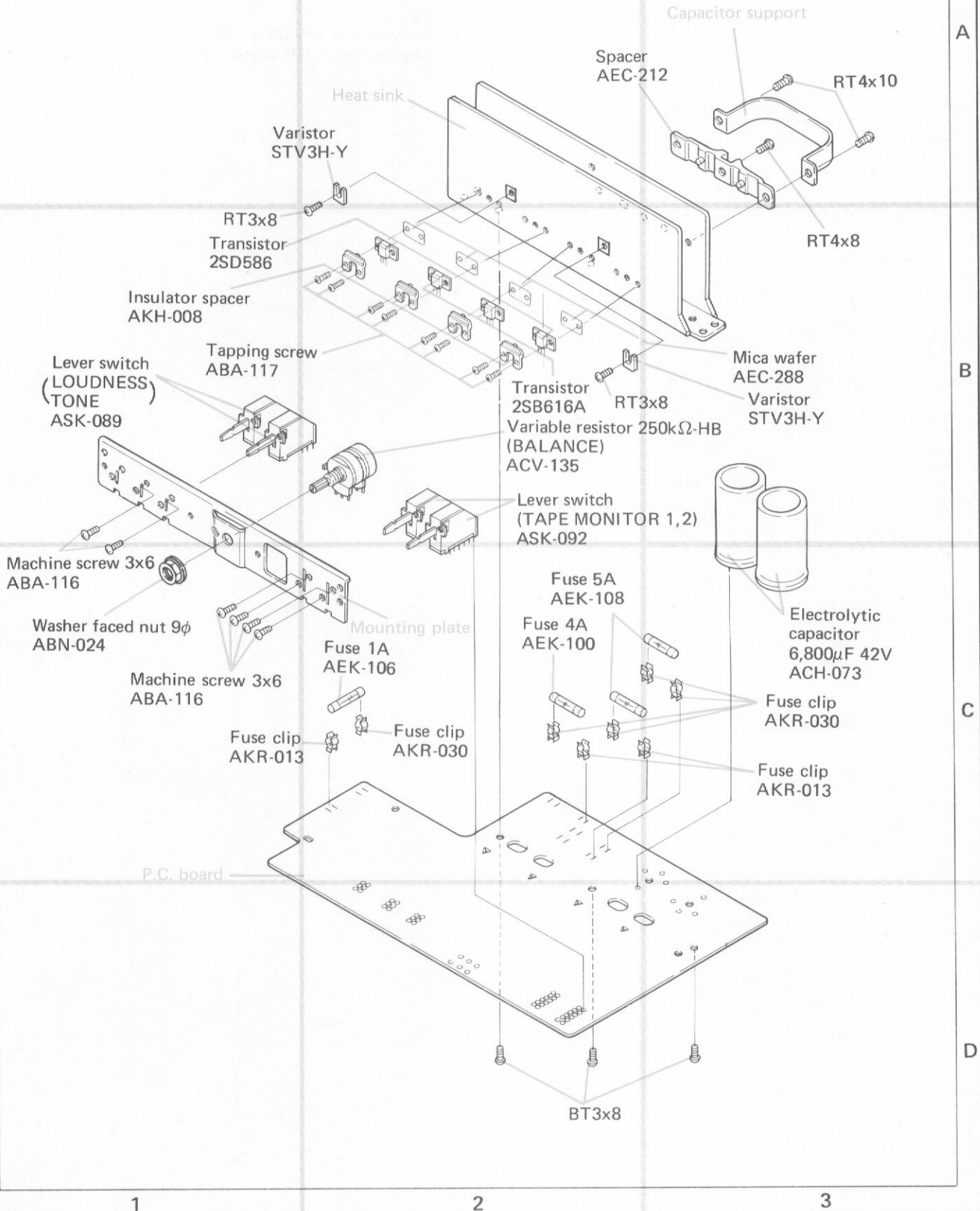

11. SCHEMATIC DIAGRAMS, P.C. BOARD PATTERNS AND PARTS LIST

11.1 MISCELLANEOUS PARTS LIST

NOTE:

- Capacitors: in μF unless otherwise noted p:pF
- Resistors: in Ω , $\frac{1}{4}W$ unless otherwise noted k:k Ω , M:M Ω

SWITCHES

Symbol	Description	Part No.
S1	Rotary switch (FUNCTION)	ASB-050
S6	Rotary switch (SPEAKERS)	ASB-021
S7	Lever switch (POWER)	ASK-065

TRANSFORMER

Symbol	Description	Part No.
T1	Power transformer	ATT-398

RESISTOR AND POTENTIOMETERS

Symbol	Description	Part No.
VR2	Variable resistor (VOLUME)100k-A	ACV-154
VR3	Variable resistor (TREBLE) 100k-A	ACV-143
VR4	Variable resistor (BASS) 100k-A	ACV-143

CAPACITORS

Symbol	Description	Part No.
C1	Ceramic 0.01 125V	ACG-003
C2	Ceramic 0.01 125V	ACG-003
C3	Ceramic 0.047 50V	CKDYF 473Z 50
C4	Ceramic 0.047 50V	CKDYF 473Z 50
C5	Ceramic 0.047 50V	CKDYF 473Z 50
C6	Ceramic 0.047 50V	CKDYF 473Z 50

LAMP AND FUSES

Symbol	Description	Part No.
PL1	Lamp with wire 8V 50mA	AEL-047
FU1	Fuse (Primary) 4A	AEK-100
FU2	Fuse (Secondary) 1A	AEK-106
FU3	Fuse (Secondary) 5A	AEK-108
FU4	Fuse (Secondary) 5A	AEK-108

● External Appearance of Transistors, IC and Thyristor

TA7136P1

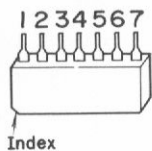

2SC1735
2SA850

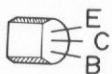

2SA640
2SC1222
2SC945A
2SA733
2SC1318
2SC1438

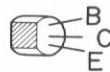

SM2B41

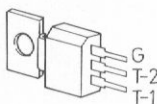

2SA777

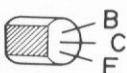

2SB616A
2SD586A

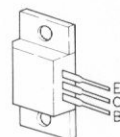

● Diagram of Rotary Switches

S₁: FUNCTION switch

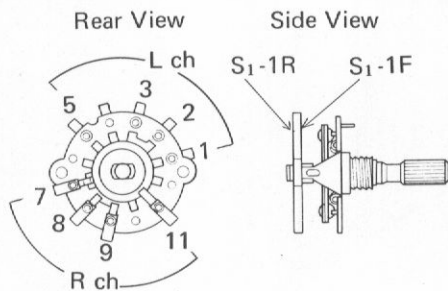

S₆: SPEAKERS switch

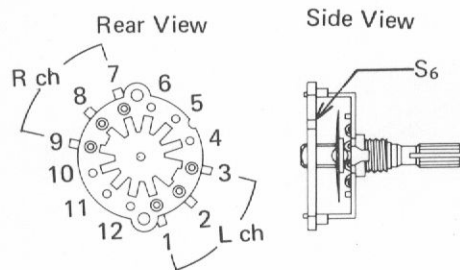

● Circuit Diagram of IC

TA7136P1

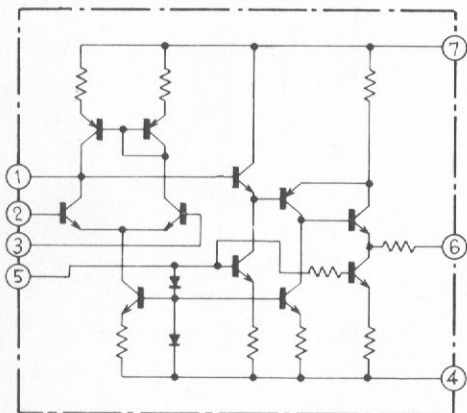

11.2 SCHEMATIC DIAGRAM

NOTE:
The indicated semiconductors are representative ones only. Other alternative semiconductors may be used and are listed in the parts list.

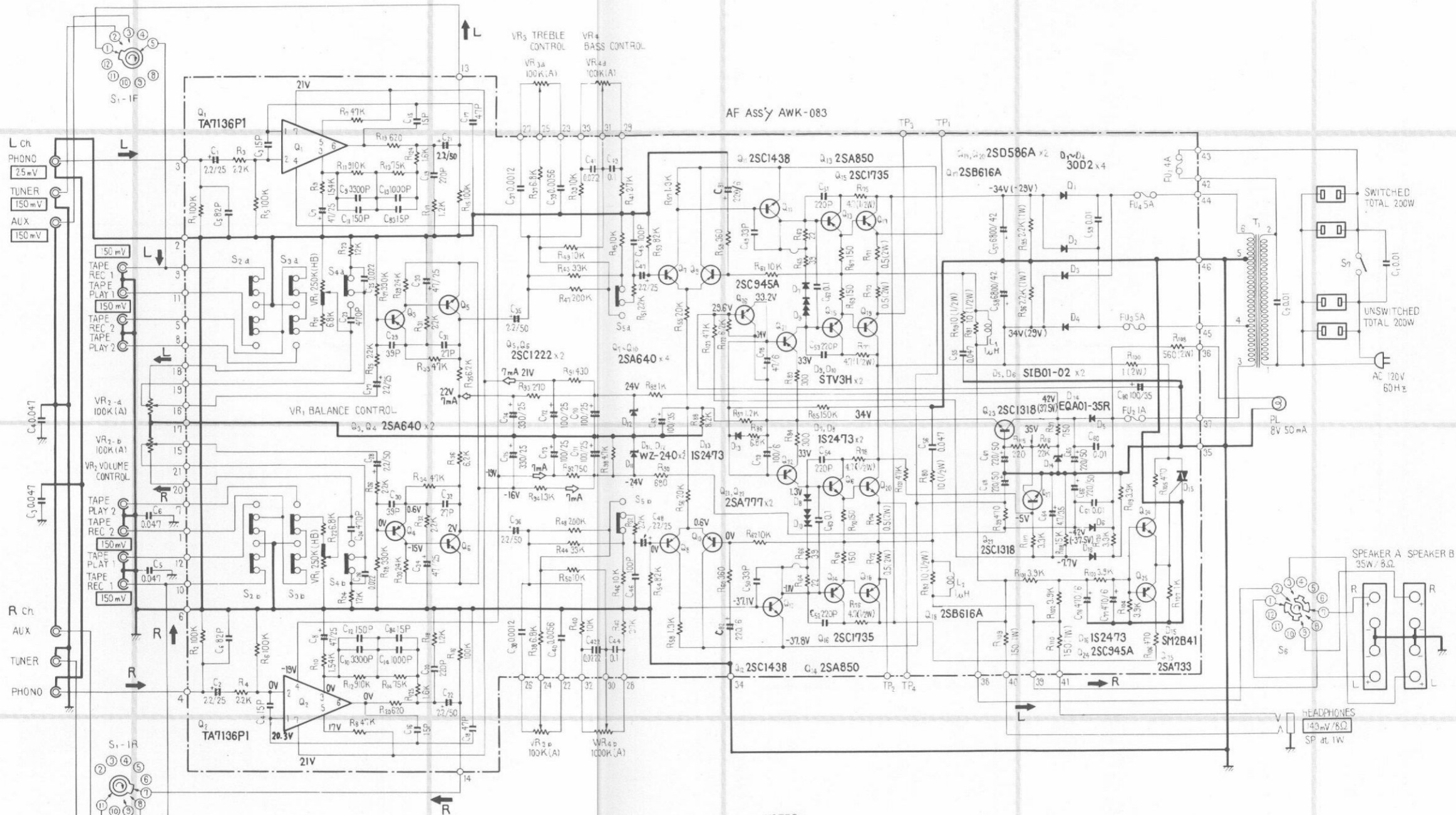

- SWITCHES:
- | | | |
|---|---|---|
| S ₁ FUNCTION
1. PHONO
2. TUNER
3. AUX | S ₃ TAPE MONITOR 2
OFF — ON | S ₆ SPEAKER SELECTOR
1. SP OFF
2. SP A
3. SP B
4. SP A+B |
| S ₂ TAPE MONITOR 1
OFF — ON | S ₄ LOUDNESS
OFF — ON | S ₇ POWER
OFF — ON |
| | S ₅ TONE
OFF — ON | |

- NOTES:
RESISTORS:
IN OHM, 1/4W, ±5% TOLERANCE UNLESS OTHERWISE NOTED K: kΩ M: MΩ
- CAPACITORS:
IN μF UNLESS OTHERWISE NOTED P: pF

- V : DC VOLTAGE AT NO INPUT SIGNAL
V : DC VOLTAGE AT 30W x2 OUTPUT
→ : DC CURRENT AT NO INPUT SIGNAL
mV : SIGNAL VOLTAGE AT 35W x1 OUTPUT (1KHz)

11.3 AF AMPLIFIER ASSEMBLY (AWK-083)

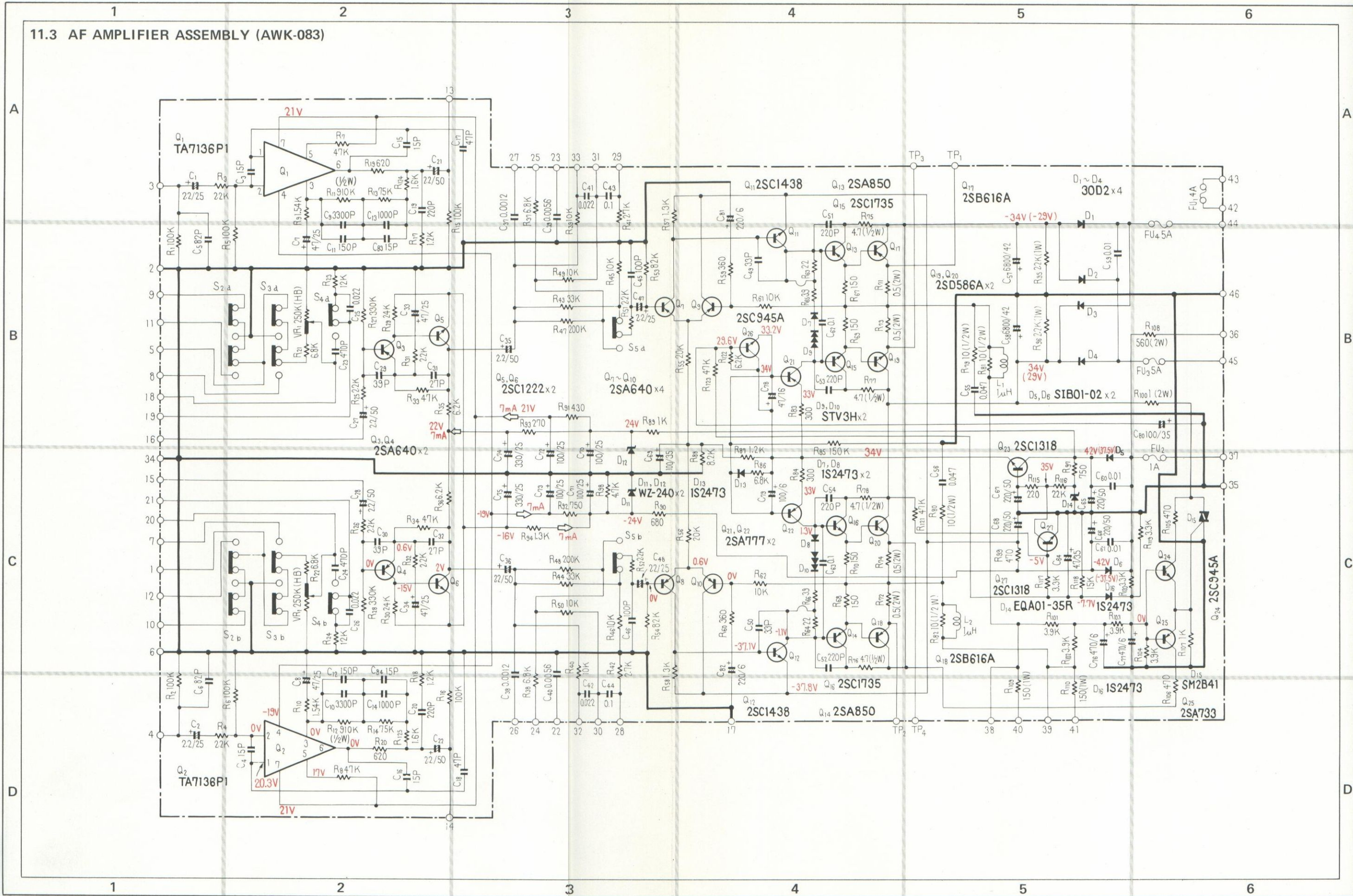

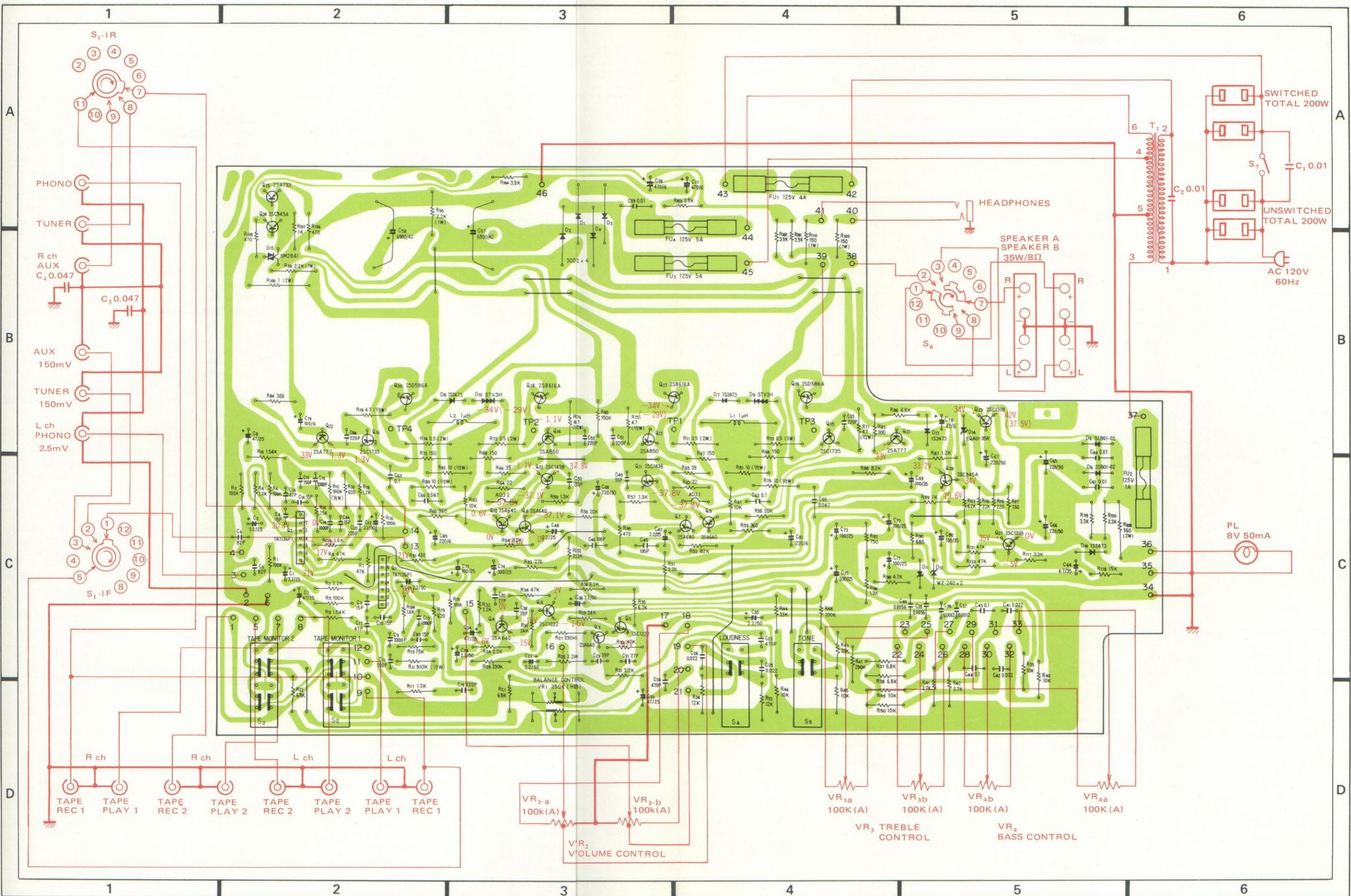

Parts List of AF Amplifier Assembly (AWK-083)

SWITCHES

Symbol	Description	Part No.
S2	Lever switch (TAPE MONITOR 1)	ASK-092
S3	Lever switch (TAPE MONITOR 2)	ASK-092
S4	Lever switch (LOUDNESS)	ASK-089
S5	Lever switch (TONE)	ASK-089

COILS

Symbol	Description	Part No.
L1	Choke coil	ATH-011
L2	Choke coil	ATH-011

CAPACITORS

Symbol	Description	Part No.
C1	Electrolytic 2.2 25V	CSZA 2R2M 25
C2	Electrolytic 2.2 25V	CSZA 2R2M 25
C3	Ceramic 15p 50V	CCDSL 150K 50
C4	Ceramic 15p 50V	CCDSL 150K 50
C5	Ceramic 82p 50V	CCDSL 820K 50
C6	Ceramic 82p 50V	CCDSL 820K 50
C7	Electrolytic 47 25V	CEANL 470P 25
C8	Electrolytic 47 25V	CEANL 470P 25
C9	Polystyrene 3300p 50V	CQSA 332G 50
C10	Polystyrene 3300p 50V	CQSA 332G 50
C11	Ceramic 150p 50V	CCDSL 151K 50
C12	Ceramic 150p 50V	CCDSL 151K 50
C13	Polystyrene 1000p 50V	CQSA 102G 50
C14	Polystyrene 1000p 50V	CQSA 102G 50
C15	Ceramic 15p 50V	CCDSL 150K 50
C16	Ceramic 15p 50V	CCDSL 150K 50
C17	Ceramic 47p 50V	CCDSL 470K 50
C18	Ceramic 47p 50V	CCDSL 470K 50
C19	Ceramic 220p 50V	CCDSL 221K 50
C20	Ceramic 220p 50V	CCDSL 221K 50
C21	Electrolytic 2.2 50V	CEANL 2R2P 50
C22	Electrolytic 2.2 50V	CEANL 2R2P 50
C23	Ceramic 470p 50V	CKDYB 471K 50
C24	Ceramic 470p 50V	CKDYB 471K 50
C25	Ceramic 0.022 50V	CKDYF 223Z 50
C26	Ceramic 0.022 50V	CKDYF 223Z 50
C27	Electrolytic 2.2 25V	CSZA 2R2M 25
C28	Electrolytic 2.2 25V	CSZA 2R2M 25
C29	Ceramic 39p 50V	CCDSL 390K 50
C30	Ceramic 39p 50V	CCDSL 390K 50
C31	Ceramic 27p 50	CCDSL 270K 50
C32	Ceramic 27p 50	CCDSL 270K 50
C33	Electrolytic 47 25V	CEANL 470P 25
C34	Electrolytic 47 25V	CEANL 470P 25
C35	Electrolytic 2.2 50V	CEANL 2R2P 50

Symbol	Description	Part No.
C36	Electrolytic 2.2 50V	CEANL 2R2P 50
C37	Ceramic 1200p 50V	CKDYB 122K 50
C38	Ceramic 1200p 50V	CKDYB 122K 50
C39	Ceramic 5600p 50V	CKDYB 562K 50
C40	Ceramic 5600p 50V	CKDYB 562K 50
C41	Mylar 0.022 50V	CQMA 223K 50
C42	Mylar 0.022 50V	CQMA 223K 50
C43	Mylar 0.1 50V	CQMA 104K 50
C44	Mylar 0.1 50V	CQMA 104K 50
C45	Ceramic 100p 50V	CCDSL 101K 50
C46	Ceramic 100p 50V	CCDSL 101K 50
C47	Electrolytic 2.2 25V	CSZA 2R2M 25
C48	Electrolytic 2.2 25V	CSZA 2R2M 25
C49	Ceramic 33p 500V	CCDSL 330K 500
C50	Ceramic 33p 500V	CCDSL 330K 500
C51	Ceramic 220p 500V	CCDSL 221K 500
C52	Ceramic 220p 500V	CCDSL 221K 500
C53	Ceramic 220p 500V	CCDSL 221K 500
C54	Ceramic 220p 500V	CCDSL 221K 500
C55	Ceramic 0.047 50V	CKDYF 473Z 50
C56	Ceramic 0.047 50V	CKDYF 473Z 50
C57	Electrolytic 6800 42V	ACH-073
C58	Electrolytic 6800 42V	ACH-073
C59	Ceramic 0.01 150V	ACG-004
C60	Ceramic 0.01 150V	ACG-004
C61	Ceramic 0.01 150V	ACG-004
C62	Mylar 0.1 50V	CQMA 104K 50
C63	Mylar 0.1 50V	CQMA 104K 50
C64	Electrolytic 4.7 35V	CEA 4R7P 35
C65	Electrolytic 220 50V	CEA 221P 50
C66	Electrolytic 220 50V	CEA 221P 50
C67	Electrolytic 220 35V	ACH-325
C68	Electrolytic 220 50V	CEA 221P 50
C69	Electrolytic 100 35V	CEA 101P 35
C70	Electrolytic 100 25V	CEA 101P 25
C71	Electrolytic 100 25V	CEA 101P 25
C72	Electrolytic 100 25V	CEA 101P 25
C73	Electrolytic 100 25V	CEA 101P 25
C74	Electrolytic 330 25V	CEA 331P 25
C75	Electrolytic 330 25V	CEA 331P 25
C76	Electrolytic 470 6V	CEA 471P 6
C77	Electrolytic 470 6V	CEA 471P 6
C78	Electrolytic 47 6V	CEA 470P 6
C79	Electrolytic 100 6V	CEA 101P 6
C80	Electrolytic 100 35V	CEA 101P 35
C81	Electrolytic 220 6V	CEA 221P 6
C82	Electrolytic 220 6V	CEA 221P 6
C83	Ceramic 15p 50V	CCDSL 150K 50
C84	Ceramic 15p 50V	CCDSL 150K 50

RESISTORS

Symbol	Description	Part No.	Symbol	Description	Part No.
R1	Carbon film 100k	RD¼PS 104JNL	R51	Carbon film 2.2k	RD¼PS 222J
R2	Carbon film 100k	RD¼PS 104JNL	R52	Carbon film 2.2k	RD¼PS 222J
R3	Carbon film 2.2k	RD¼PS 222J	R53	Carbon film 82k	RD¼PS 823JNL
R4	Carbon film 2.2k	RD¼PS 222J	R54	Carbon film 82k	RD¼PS 823JNL
R5	Carbon film 100k	RD¼PS 104JNL	R55	Carbon film 20k	RD¼PS 203J
R6	Carbon film 100k	RD¼PS 104JNL	R56	Carbon film 20k	RD¼PS 203J
R7	Carbon film 47k	RD¼PS 473J	R57	Carbon film 1.3k	RD¼PS 132J
R8	Carbon film 47k	RD¼PS 473J	R58	Carbon film 1.3k	RD¼PS 132J
R9	Metal film 1.54k	RN¼PT 1541F	R59	Carbon film 360	RD¼PS 361J
R10	Metal film 1.54k	RN¼PT 1541F	R60	Carbon film 360	RD¼PS 361J
R11	Metal film 910k ½W	RN¼PT 9103F	R61	Carbon film 10k	RD¼PS 103J
R12	Metal film 910k ½W	RN¼PT 9103F	R62	Carbon film 10k	RD¼PS 103J
R13	Metal film 75k	RN¼PT 7502F	R63	Carbon film 22	RD¼PS 220J
R14	Metal film 75k	RN¼PT 7502F	R64	Carbon film 22	RD¼PS 220J
R15	Carbon film 100k	RD¼PS 104J	R65	Carbon film 39	RD¼PS 390J
R16	Carbon film 100k	RD¼PS 104J	R66	Carbon film 39	RD¼PS 390J
R17	Carbon film 1.2k	RD¼PS 122J	R67	Carbon film 150	RD¼PSF 151J
R18	Carbon film 1.2k	RD¼PS 122J	R68	Carbon film 150	RD¼PSF 151J
R19	Carbon film 620	RD¼PS 621J	R69	Carbon film 150	RD¼PSF 151J
R20	Carbon film 620	RD¼PS 621J	R70	Carbon film 150	RD¼PSF 151J
R21	Carbon film 6.8k	RD¼PS 682J	R71	Metal film 0.5 2W	RN2H 0R5K
R22	Carbon film 6.8k	RD¼PS 682J	R72	Metal film 0.5 2W	RN2H 0R5K
R23	Carbon film 12k	RD¼PS 123J	R73	Metal film 0.5 2W	RN2H 0R5K
R24	Carbon film 12k	RD¼PS 123J	R74	Metal film 0.5 2W	RN2H 0R5K
R25	Carbon film 2.2k	RD¼PS 222J	R75	Carbon film 4.7 ½W	RD¼PSF 4R7J
R26	Carbon film 2.2k	RD¼PS 222J	R76	Carbon film 4.7 ½W	RD¼PSF 4R7J
R27	Carbon film 330k	RD¼PS 334JNL	R77	Carbon film 4.7 ½W	RD¼PSF 4R7J
R28	Carbon film 330k	RD¼PS 334JNL	R78	Carbon film 4.7 ½W	RD¼PSF 4R7J
R29	Carbon film 24k	RD¼PS 243J	R79	Carbon film 10 ½W	RD¼PSF 100J
R30	Carbon film 24k	RD¼PS 243J	R80	Carbon film 10 ½W	RD¼PSF 100J
R31	Carbon film 2.2k	RD¼PS 222J	R81	Carbon film 10 ½W	RD¼PSF 100J
R32	Carbon film 2.2k	RD¼PS 222J	R82	Carbon film 10 ½W	RD¼PSF 100J
R33	Carbon film 47k	RD¼PS 473JNL	R83	Carbon film 300	RD¼PS 301J
R34	Carbon film 47k	RD¼PS 473JNL	R84	Carbon film 300	RD¼PS 301J
R35	Carbon film 6.2k	RD¼PS 622J	R85	Carbon film 150k	RD¼PS 154J
R36	Carbon film 6.2k	RD¼PS 622J	R86	Carbon film 6.8k	RD¼PS 682J
R37	Carbon film 6.8k	RD¼PS 682J	R87	Carbon film 1.2k	RD¼PS 122J
R38	Carbon film 6.8k	RD¼PS 682J	R88	Carbon film 8.2k	RD¼PS 822J
R39	Carbon film 10k	RD¼PS 103J	R89	Carbon film 1k	RD¼PS 102J
R40	Carbon film 10k	RD¼PS 103J	R90	Carbon film 680	RD¼PS 681J
R41	Carbon film 2.7k	RD¼PS 272J	R91	Carbon film 430	RD¼PS 431J
R42	Carbon film 2.7k	RD¼PS 272J	R92	Carbon film 750	RD¼PS 751J
R43	Carbon film 33k	RD¼PS 333J	R93	Carbon film 270	RD¼PS 271J
R44	Carbon film 33k	RD¼PS 333J	R94	Carbon film 1.3k	RD¼PS 132J
R45	Carbon film 10k	RD¼PS 103J	R95	Metal oxide film 2.2k 1W	RS1P 222J
R46	Carbon film 10k	RD¼PS 103J	R96	Metal oxide film 2.2k 1W	RS1P 222J
R47	Carbon film 200k	RD¼PS 204J	R97	Carbon film 750	RD¼PS 751J
R48	Carbon film 200k	RD¼PS 204J	R98	Carbon film 4.7k	RD¼PS 472J
R49	Carbon film 10k	RD¼PS 103J	R99	Carbon film 470	RD¼PSF 471J
R50	Carbon film 10k	RD¼PS 103J	R100	Metal film 1 2W	RN2H 010K

Symbol	Description	Part No.
R101	Carbon film 3.9k	RD¼PS 392J
R102	Carbon film 3.9k	RD¼PS 392J
R103	Carbon film 3.9k	RD¼PS 392J
R104	Carbon film 3.9k	RD¼PS 392J
R105	Carbon film 470	RD¼PS 471J
R106	Carbon film 470	RD¼PS 471J
R107	Carbon film 1k	RD¼PS 102J
R108	Metal oxide film 560 2W	RS2P 561J
R109	Metal oxide film 150 1W	RS1P 151J
R110	Metal oxide film 150 1W	RS1P 151J
R111	Carbon film 100k	RD¼PS 104J
R112	Carbon film 100k	RD¼PS 104J
R113	Carbon film 390k	RD¼PS 394J
R114	Carbon film 390k	RD¼PS 394J
R115	Carbon film 220	RD¼PS 221J
R116	Carbon film 22k	RD¼PS 223J
R117	Carbon film 3.3k	RD¼PS 332J
R118	Carbon film 15k	RD¼PS 153J
R119	Carbon film 3.3k	RD¼PS 332J
R120	Carbon film 3.3k	RD¼PS 332J
R121	Carbon film 47k	RD¼PS 473J
R122	Carbon film 6.2k	RD¼PS 622J
R123	Carbon film 47k	RD¼PS 473J
R124	Carbon film 1.6k	RD¼PS 162J
R125	Carbon film 1.6k	RD¼PS 162J
VR1	Variable resistor (BALANCE) 250k-HB	ACV-135

Symbol	Description	Part No.
Q21	Transistor	2SA777-R or Q
Q22	Transistor	2SA777-R or Q
Q23	Transistor	2SC1318-R or Q
Q24	Transistor	2SC945A-Q or R
Q25	Transistor	2SA733-Q or R
Q26	Transistor	2SC945A-Q or R
Q27	Transistor	2SC1318-R or Q
D1	Diode	ERC01-02 (30D2)
D2	Diode	ERC01-02 (30D2)
D3	Diode	ERC01-02 (30D2)
D4	Diode	ERC01-02 (30D2)
D5	Diode	SIB01-02 (1S1886)
D6	Diode	SIB01-02 (1S1886)
D7	Diode	1S2473
D8	Diode	1S2473
D9	Varistor	STV3H-Y
D10	Varistor	STV3H-Y
D11	Zener diode	WZ-240
D12	Zener diode	WZ-240
D13	Diode	1S2473
D14	Zener diode	EQA-01-35R
D15	Thyristor	SM2B41
D16	Diode	1S2473

SEMICONDUCTORS

Symbol	Description	Part No.
Q1	IC	TA7136P1
Q2	IC	TA7136P1
Q3	Transistor	2SA640-E or F
Q4	Transistor	2SA640-E or F
Q5	Transistor	2SC1222-E or F
Q6	Transistor	2SC1222-E or F
Q7	Transistor	2SA640-E or F
Q8	Transistor	2SA640-E or F
Q9	Transistor	2SA640-E or F
Q10	Transistor	2SA640-E or F
Q11	Transistor	2SC1438-V or B
Q12	Transistor	2SC1438-V or B
Q13	Transistor	2SA850-C or D
Q14	Transistor	2SA850-C or D
Q15	Transistor	2SC1735-C or D
Q16	Transistor	2SC1735-C or D
Q17	Transistor	2SB616A-R or Q
Q18	Transistor	2SB616A-R or Q
Q19	Transistor	2SD586A-R or Q
Q20	Transistor	2SD586A-R or Q

12. PACKING

